

# ROYAL PRODUCTS

## **Rota-Rack**™

### Rotary Parts Accumulator

*The Perfect  
Bar Feed  
Companion*

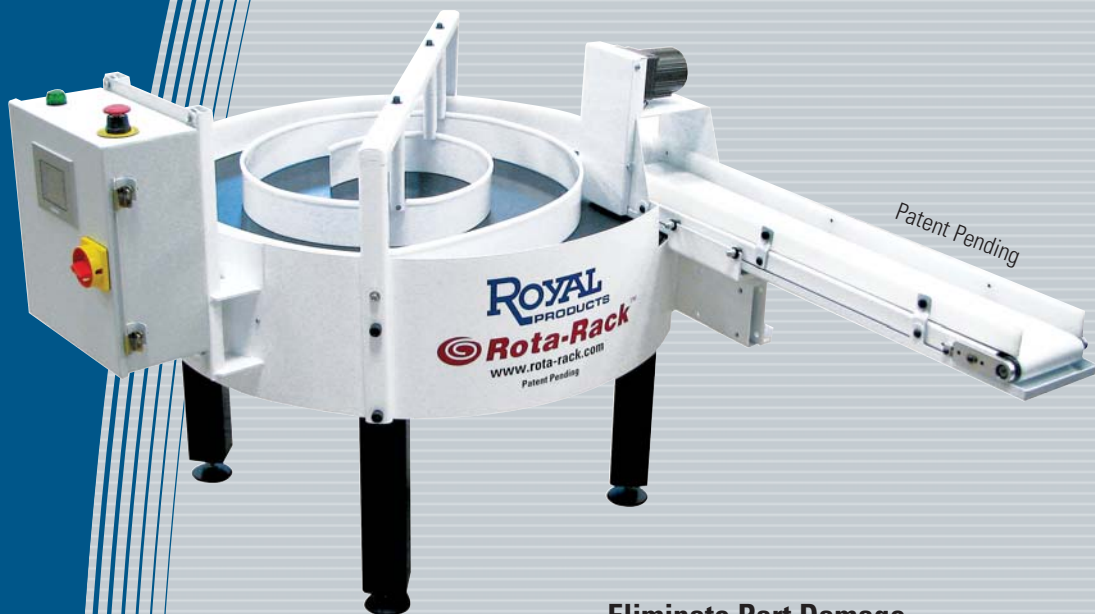

- Eliminate Part Damage
- Run Your CNC Lathes Completely Unattended for Hours at a Time
- Keep Parts in Order for QC Purposes
- Pays for Itself in Just a Few Months



5 PM – Tuesday



11 PM – Tuesday



6 AM – Wednesday

# ROTA-RACK™ ROTARY PARTS ACCUMULATOR



The patent-pending Royal Rota-Rack™ is a lean, cost-effective device designed to safely collect finished parts as they come off of a CNC lathe, providing true lights-out production.

We originally developed the Rota-Rack™ for use in our own factory because we needed a better way to manage the large volumes of live center and collet chuck components we produce.

The traditional collection method of using wooden boxes didn't adequately protect our parts, and oil-filled tubs were too messy. The other problem was that neither of these approaches accommodated enough parts to allow the machines to run unattended for extended periods of time.

**Now, thanks to the Rota-Rack™, our CNC lathes continue making parts long after our last employee leaves for the night or weekend. How much additional profit would you make if you could run a 2nd or 3rd shift with your existing equipment and no additional employees?**

**The Royal Rota-Rack™  
is very simple to  
setup and operate.  
Here's how it works:**



User enters the part cycle time and degree of turntable rotation via a simple PLC controller. A counter can also be set to shut the Rota-Rack down after a specified number of parts have been collected.



As a finished part comes out of the lathe, it drops onto the conveyor and is moved towards the Rota-Rack's™ rotating turntable.



Each time a part comes out of the machine, the Rota-Rack™ indexes to the next position. The degree of turntable rotation is easily adjusted according to part length.



As the turntable indexes, the parts are gently guided towards the center of unit via the spiral.



After several hours of unmanned production, finished parts are removed from the center of the Rota-Rack™.

# ROTA-RACK™ ROTARY PARTS ACCUMULATOR

ROYAL  
PRODUCTS

## Large Capacity

With over 850 square inches of surface area, the Royal Rota-Rack™ can hold hundreds of parts<sup>1</sup> and provide hours of unmanned operation.

## Excellent Part Protection

Low-friction UHMW coating on the turntable and spiral protects finished parts from scuffs and dents.



## Heavy-Duty Construction

The heavy steel welded construction of the Royal Rota-Rack™ is built to withstand years of abuse in the harshest production environments. Payload capacity is 700 lbs.

## Pays for Itself

The Royal Rota-Rack pays for itself in just a few short months by enabling you to run your CNC lathes completely unattended for extended periods of time.

## Unique Rotary Spiral

Gently guides finished parts to the center as the turntable rotates.

## No Machine Interface Required

The operator sets the part cycle time, degree of turntable advancement, and part counter/auto-shutoff with a simple PLC controller.<sup>2</sup>

## Optional Conveyor

An optional conveyor bolts directly to the Rota-Rack™ and is connected with a pre-wired plug for simple, hassle-free installation.

## Universal Design

The Royal Rota-Rack™ adapts to any CNC lathe that is equipped with a part catcher:

- Turntable can rotate either clockwise or counter-clockwise, and can be positioned to either the left side or right side of the lathe
- Height adjustable from 10.5 – 44 inches standard. Other height requirements can be accommodated upon special request
- Rota-Rack™ is completely free standing – no bolting to the machine or floor is required
- Easily adapts to machines with existing conveyors

## Popular Rota-Rack™ Applications:

- CNC Lathes
- Multitasking Machines
- Swiss-Type CNC's
- Automatic Saws
- Robot Loaders
- Custom Machinery

**The Royal Rota-Rack™ is reliable, doesn't take sick days, and pays for itself within a few months of use. Order yours today and get a jump on your competition!**

<sup>1</sup>Actual number of parts depends upon individual part size

<sup>2</sup>Unit can also be controlled via M-function from the machine. Contact Royal Products for further information.

## Flexible Positioning

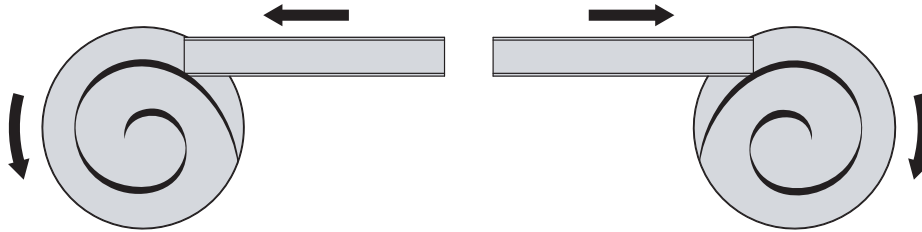

### Left-Hand Orientation

Turntable Rotates  
Counter-Clockwise

### Right-Hand Orientation

Turntable Rotates  
Clockwise

The universal design of the Royal Rota-Rack™ enables it to be mounted to either the left-hand or right-hand side of the machine's part catcher basket. The PLC control box can mount in three different locations on the housing for optimum positioning.

## Rota-Rack™ Specifications

Turntable Diameter	36"
Conveyor Length	36"
Max. Part Length	10"
Min. Part Diameter	0.25"
Payload Capacity	700 lbs.
Height Range	10.5" – 44"
Power Supply	110 V, 60 Hz.
Index Adjustment Range	1 second – 999 hours

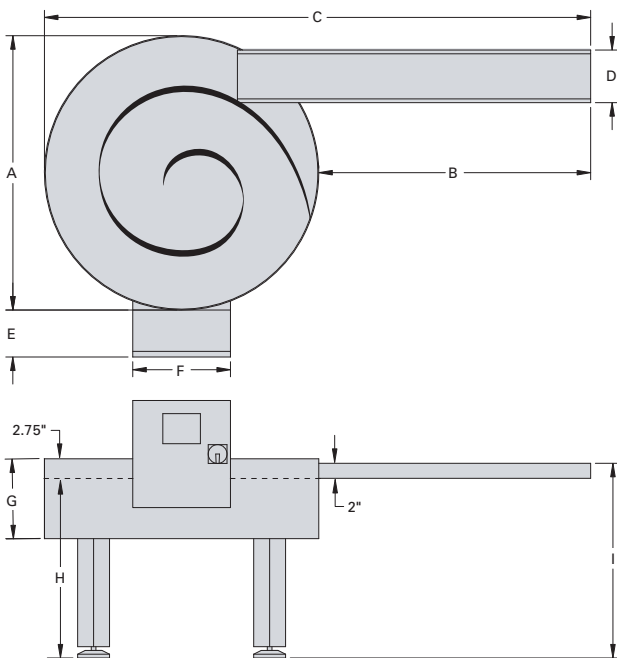

## Dimensions

A	36"
B	36"
C	70.12"
D	8"
E	7.88"
F	13.5"
G	10.75"
H	42"/10.5"
I	44"/12.5"

**Alternate sizes and specifications available as special order.**

**Please contact a Royal Products applications engineer to discuss your requirements.**

## Frequently Asked Questions

### **Q.** How does the Royal Rota-Rack™ handle long parts?

**A.** There is no absolute answer to this question because part diameter, shape, and weight also figure into the scenario. However, as a general rule, the standard Rota-Rack™ will handle workpieces measuring up to 10" long x 3" in diameter, and longer parts can often be accommodated with a slight spiral modification.

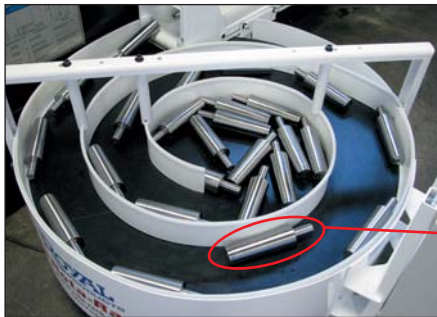

Example:  
5 MT Live Center Shank  
Length: 7.25"  
Diameter: 1.75"  
Weight: 3.4 lbs.



**Free Performance Evaluation** – If you are not sure if the Rota-Rack™ will work for you, send us a few of your parts to check out. We'll run them through a Rota-Rack™ in our shop and send you a video of the results. For further information, please contact one of our applications engineers at 1-800-645-4174.

### **Q.** Does the Rota-Rack™ prevent part scratching?

**A.** One of the key benefits of the Royal Rota-Rack™ is its ability to protect workpiece surface finishes. Both the spiral and turntable are coated with a high lubricity UHMW (plastic) material to minimize friction. It is important to note that when parts begin to accumulate in the center of the turntable, they will rub against each other. However, the motion is slow, smooth, and intermittent, which results in minimal impact and damage. While it is not possible to guarantee complete protection against scratching, we know of no other method that will protect parts better than the Royal Rota-Rack™.

### **Q.** Does a lathe need to be modified to accommodate the Rota-Rack™?

**A.** In order for a machine to use the Royal Rota-Rack, there must be some way to get finished parts out of the spindle. On most lathes, this is accomplished with a part catcher that transfers completed parts to some type of collection box. It may be necessary to perform a simple modification to your collection box by cutting out the bottom and side of the box so that parts can pass through to the conveyor. When purchasing a new machine, it may be possible to order the machine as "conveyor-ready" which means that this simple modification will already have been made.



### **Q.** Are other size Rota-Racks™ and conveyors available?

**A.** Yes. Please contact a Royal Products applications engineer at 1-800-645-4174 to discuss your requirements.

## Royal Rota-Rack™ Parts Accumulator



- ❑ Height adjustable from 10.5 – 44 inches with included legs.
- ❑ Large 36" diameter turntable provides hours of unmanned operation.
- ❑ Turntable and spiral are covered with special UHMW material for maximum lubricity and part protection.
- ❑ No machine interface required – user enters the part cycle time and degree of turntable rotation via a simple PLC controller. A counter can also be set to shut the Rota-Rack down after a specified number of parts have been collected.
- ❑ Universal design allows for both left-hand and right-hand positioning.
- ❑ Operates on standard 110 volt power.
- ❑ White powder-coated finish.
- ❑ Order optional conveyor separately.

**Catalog Number 51002**

## Conveyor



- ❑ Optional conveyor moves parts from machine's part catcher collection box\* to the Rota-Rack™.
- ❑ Standard conveyor length is 36". Other lengths available as special order.
- ❑ Mounts securely to Rota-Rack™ frame with supplied hardware – no need to bolt to lathe and no legs to interfere with foot controls.
- ❑ Easily connects to PLC control with an included pre-wired power cord.
- ❑ Includes drip-pan with drain for coolant recovery.

**Catalog Number 51022**

**Call 1-800-645-4174 for pricing**

\* Note: it may be necessary to modify machine's part catcher collection box in order to allow parts to drop onto the conveyor. For additional information, please contact a Royal Products applications engineer at 1-800-645-4174.