

# 5C EXPANDING COLLETS

- ❑ Unlike chucks and most collets that grip the OD of a workpiece, 5C expanding collets are designed to grip on the ID of a part.
- ❑ Accu-length design ensures precise workpiece positioning — no z-axis movement.
- ❑ Collet head is easily machined to required size. Can be re-machined as necessary.
- ❑ Concentricities of  $\pm 0.0002$ " can typically be achieved using Royal 5C expanding collets.
- ❑ Made from 1144 steel that can be hardened after machining for wear resistance.
- ❑ Additional head lengths and diameters available. Contact us for information.



Head is easily machined to required size by customer. See chart for range.

Precision ground body for excellent workpiece concentricity.

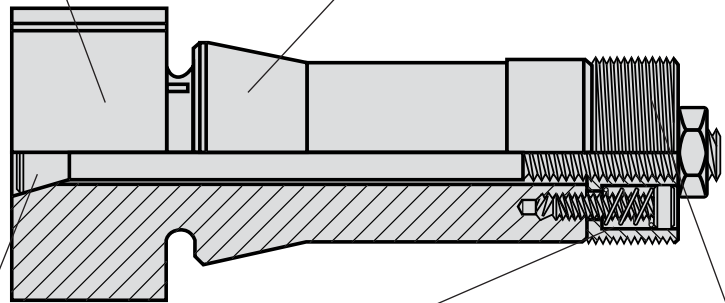

Expanding rod is hardened and ground for strength and durability.

Internal spring provides positive release.

Rear threaded section is separate from collet body. When this section is pulled back by the drawtube, it pulls the tapered expanding rod back, causing the head to expand.

## Royal 5C Internal Expanding Collets

NOMINAL HEAD DIAMETER	HEAD LENGTH	MACHINEABLE RANGE MIN-MAX	CATALOG NO.	PRICE
3/4"	1"	1/4" - 11/16"	20100	<b>\$90</b>
1"	1"	7/16" - 15/16"	20101	<b>90</b>
1 1/2"	1"	3/4" - 1 1/16"	20102	<b>90</b>
1 1/2"	1 1/2"	3/4" - 1 7/16"	20103	<b>104</b>
1 1/2"	2"	3/4" - 1 7/16"	20104	<b>105</b>
2"	1"	3/4" - 1 15/16"	20107	<b>109</b>
2"	1 1/2"	3/4" - 1 15/16"	20108	<b>114</b>
2"	2"	3/4" - 1 15/16"	20109	<b>130</b>
2 1/2"	1"	3/4" - 2 7/16"	20112	<b>133</b>
3"	1"	3/4" - 2 15/16"	20117	<b>146</b>
5"	2"	3/4" - 4 15/16"	20127	<b>282</b>
6"	2"	3/4" - 5 15/16"	20128	<b>315</b>

## Replacement Expanding Rods

HEAD DIA.	HEAD LENGTH	CAT. NO.	PRICE
3/4"	1"	20135	<b>\$29</b>
1"	1"	20136	<b>26</b>
1 1/2"-6"	1"	20130	<b>20</b>
1 1/2"-6"	1 1/2"	20131	<b>21</b>
1 1/2"-6"	2"	20132	<b>22</b>