

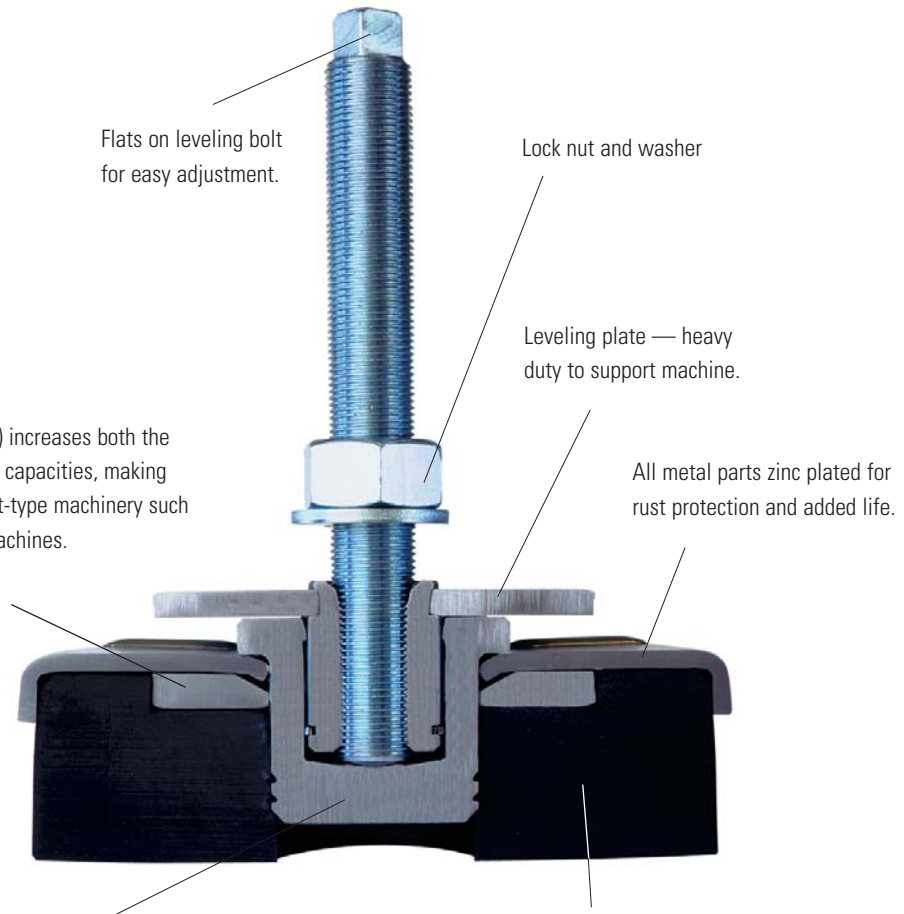

- Royal machine mounts are built tough to level and last. All metal parts are zinc plated for rust protection and long life.
- Royal machine mounts simplify machine installation, reduce noise, and isolate vibration.
- Great for injection molding machines, presses, lathes, mills, and grinders.
- These mounts **meet OSHA requirements** by preventing machines from “walking” without the need for bolting or cementing.
- All Royal machine mounts incorporate a large, chloroprene rubber base that is resistant to oil, water, and many chemicals.
- Support cup is machined from a solid bar instead of deep drawn, resulting in increased thickness for strength and rigidity.
- Unique internal retaining clip ensures that mounts will stay together if machine is moved to a new location.
- Royal machine mounts protect sensitive machine components, improve performance, and reduce maintenance costs.

Royal Machine Mounts are Built Tough to Level and Last!

Shock plate (models #4 and #5 only) increases both the vertical and horizontal load carrying capacities, making these an excellent choice for impact-type machinery such as presses and injection molding machines.



Heavy-duty support cup is machined from a solid steel bar for strength. Other brands rely on a thin drawn cup which often fails by fatigue. Note the increased thickness of the lip and bottom sections.

Thick chloroprene base is resistant to most chemicals.

Choosing the Correct Royal Machine Mounts

1. Calculate the load on each mount by dividing the total weight of the machine by the number of mounting locations.

Note: sometimes it may be necessary to compensate for machines that do not have an evenly distributed load.

2. Find the category in the specification chart which corresponds to the type of machine being installed.
3. Match up the correct mount with the machine.

Example: Suppose you wish to mount an 18,000-lb. CNC lathe which has six mounting locations.

$$18,000/6=3,000 \text{ lbs. per mount}$$

From the chart on the next page we see that this machine falls into the range of the #3 mount for non-impact machinery.

Warning: Always use the correct mount for each machine. These mounts are not designed for machines that must be bolted to the floor to prevent tipping. If you have any questions, please contact one of our application engineers at 1-800-645-4174.

Royal Machine Mounts

		#1	#2	#3	#4	#5
Load Range per Mount (lbs.)	General Non-Impact Machinery	100–1,100	880–2,200	1,760–5,500	3,300–8,800	6,600–12,000
	Injection Molding Machines	390 max.	790 max.	2,180 max.	5,450 max.	8,220 max.
	Presses up to 125 strokes / min	150–440	440–880	880–3,080	3,080–5,940	5,940–8,800
	up to 180 strokes / min	130–300	300–770	770–2,420	2,420–4,290	4,290–7,700
Mount Dimensions	up to 200 strokes / min	110–260	260–550	550–1,760	1,760–2,860	2,860–5,280
	Base Diameter	3.16	4.75	6.31	6.31	7.88
	Leveling Plate Diameter	2.38	3.12	3.93	3.93	3.93
	Height to Top of Leveling Plate	1.63	1.94	2.31	2.31	2.72
	Height to Top of Bolt	5.25	5.25	7.50	7.50	7.88
	Leveling Bolt Size	M12 x 1.25	M16 x 1.5	M20 x 1.5	M20 x 1.5	M20 x 1.5
	Standard Leveling Bolt	4.72	4.72	6.88	6.88	6.88
Ordering Info	Level Adjustment	0.88	0.88	1.00	1.00	1.00
	Catalog Number	27001	27002	27003	27004	27005
	Price Each	\$23	\$44	\$61	\$73	\$120

Extra-Long Leveling Bolts

For machines with thick bases.

MOUNT TYPE	BOLT SIZE	BOLT LENGTH	CAT. NO.	PRICE
#1	M12 x 1.25	8¼"	27007	\$9
#2	M16 x 1.5	8¼"	27008	10
#3–#5	M20 x 1.5	9¾"	27009	18

Easy Installation — No drilling or bolting to floor required

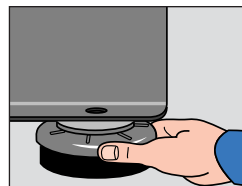

Raise machine and slide mount into place.

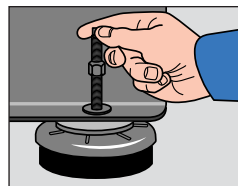

Insert leveling bolt through machine base hole and thread into mount. Lower machine onto leveling plate.

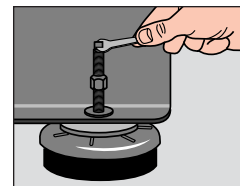

Raise or lower machine by turning leveling bolt.

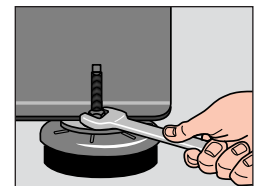

When machine is level, secure in place with washer and lock nut.